



DAFO
Vehicle
BY UNITED SAFETY

MANUAL

Carbon Monoxide Monitoring System for Lithium-Ion Battery Safety in Electric Vehicles



Designed specifically for electric vehicles undergoing maintenance, our Carbon Monoxide Sensing System offers critical safety monitoring in automobile repair facilities. Sensing early signs of Lithium-Ion battery venting, this system is an indispensable safety solution for any service center dealing with electric vehicles. Featuring innovative, patent-pending technology our system sets a new standard in safety monitoring.



Important Product Usage Information

Specialized EV-Garm for Lithium-Ion Battery Monitoring

Our EV-Garm is engineered specifically to monitor environments where Lithium-Ion batteries are present and possibly damaged. It is important to note that this device is **not** designed or certified as a health and safety carbon monoxide detector according to UL2075, IEC 50291-1, or similar standards typically used for residential or commercial safety applications.

Purpose of This Device:

Battery Safety Alert: The primary function of this system is to detect the presence of carbon monoxide as an early indicator of potential distress or failure in Lithium-Ion batteries. It alerts users to the possibility of a battery venting or other malfunction, which could lead to hazardous conditions if not addressed promptly.

Technical Monitoring Tool: This system is a technical tool intended for use in professional and industrial settings where precise monitoring of battery health and safety is critical. It provides alerts that allow for timely preventative maintenance or emergency measures to be taken before a battery incident escalates.

Not a Substitute for Health-Related CO Detectors:

- **Specific Use Case:** While our device detects carbon monoxide, it does so to facilitate the monitoring of battery health, not to provide alerts based on health safety thresholds. As such, it should not be used as a substitute for health and safety carbon monoxide detectors designed for personal safety in homes or workplaces.
- **Alerting Mechanism:** The alert thresholds and parameters are configured with the specific chemistry and behavior of Lithium-Ion batteries in mind, which differ from the configurations used in CO detectors that are designed to protect individuals from the health risks associated with carbon monoxide exposure.

We strongly recommend that customers continue to use certified health and safety carbon monoxide detectors in conjunction with our product to ensure comprehensive safety coverage in environments where both personnel and sensitive equipment are present.



IMPORTANT PRODUCT USAGE INFORMATION	2
GENERAL INFORMATION	5
UNDERSTANDING THE HAZARDS: THERMAL RUNAWAY AND TOXIC GAS EMISSIONS IN LITHIUM-ION BATTERIES	5
WHAT IS THERMAL RUNAWAY?	5
TOXIC GASES FROM BATTERY VENTING OR FIRE	5
WHY MONITOR FOR CARBON MONOXIDE?	5
IMPORTANCE OF EARLY DETECTION SYSTEMS.....	5
EARLY ALERT:	5
HEALTH AND SAFETY COMPLIANCE:.....	5
OPERATIONAL CONTINUITY:	5
YOUR SAFETY PARTNER IN LITHIUM-ION BATTERY MAINTENANCE	5
WHAT TO DO IN CASE OF AN ALERT FROM EV-GARM	6
SYSTEM DESCRIPTION	7
CONTROL UNIT.....	7
INTEGRATED CONTROL AND MONITORING FEATURES	7
SENSOR MODULE DESCRIPTION	9
INTEGRATED SYSTEM FUNCTIONALITY.....	10
OPERATIONAL BENEFITS	10
WARRANTY AND SPARE PARTS INFORMATION	11
WARRANTY COVERAGE	11
WHAT THE WARRANTY COVERS:.....	11
WHAT THE WARRANTY DOES NOT COVER:	11
SPARE PARTS.....	11
ORDERING SPARE PARTS:	11
EXTENDED WARRANTY AND SERVICE PLANS	11
CUSTOMER SUPPORT.....	11
GUARANTEE TERMS AND CONDITIONS	12
DISCLAIMER AND SAFETY INFORMATION	13
OPERATING INSTRUCTIONS	15
SETTING UP WiFi AND PAIRING YOUR EV-GARM DEVICE	15
SETTING UP EMAIL ALERTS FOR EV-GARM	15
HOW TO ACTIVATE NFC ON YOUR MOBILE DEVICE	16
SENSOR MANAGEMENT	17
COMPLETION.....	18
UNDERSTANDING LED INDICATORS ON YOUR EV-GARM SYSTEM	19
LED INDICATOR MEANINGS:	19
ADDITIONAL INFORMATION ON FAULTS:	20
ACTION REQUIRED:.....	20
INSTALLATION STEPS PRE-USAGE PREPARATION	20
SELECT THE INSTALLATION LOCATION	21
MOUNT THE SENSOR	21



EV-Garm

VERIFY FUNCTIONALITY 21
POSITIONING GUIDANCE 21
EXAMPLE OF PROPER MOUNTING..... 22

HANDLING AND MAINTENANCE OF YOUR EV-GARM SYSTEM 22

GENERAL MAINTENANCE TIPS: 22
STORAGE RECOMMENDATIONS: 23
SENSOR MAINTENANCE:..... 23
UNDERSTANDING CROSS SENSITIVITY TO OTHER GASES 23

REGULATORY COMPLIANCE 23

TECHNICAL SPECIFICATIONS 24



General information

Understanding the Hazards: Thermal Runaway and Toxic Gas Emissions in Lithium-Ion Batteries

What is Thermal Runaway? Thermal runaway occurs when an increase in temperature changes the conditions in a way that causes a further increase in temperature, often leading to a destructive reaction or fire. In Lithium-Ion batteries, this can be triggered by battery malfunction, design flaws, physical damage, or external heat sources. The reaction is rapid and can escalate quickly, posing serious fire and explosion risks.

Toxic Gases from Battery Venting or Fire When Lithium-Ion batteries undergo thermal runaway, they can emit toxic gases, including carbon monoxide (CO), hydrogen fluoride (HF), and other harmful compounds. These gases can pose severe health risks, including respiratory issues, chemical burns, and other acute health effects. Early detection of these gases is crucial for safety and effective emergency response.

Why Monitor for Carbon Monoxide?

Carbon monoxide is a colorless, odorless gas that can be lethal in high concentrations but is also one of the earliest detectable signs of battery venting or thermal runaway. Monitoring CO levels provides a critical early alert, enabling swift action to mitigate the risk of fire and severe health hazards.

Importance of Early Detection Systems

Installing a EV-Garm is essential in environments where Lithium-Ion batteries are used and maintained, such as electric vehicle service centers. These systems provide the following benefits:

Early Alert: Allows for immediate response to prevent escalation and safeguard both personnel and property.

Health and Safety Compliance: Helps ensure workplace safety standards are met, protecting employees and complying with occupational health regulations.

Operational Continuity: Prevents extensive damage to facilities and the costly downtime associated with battery fires and related incidents.

Your Safety Partner in Lithium-Ion Battery Maintenance

Our EV-Garm is designed to address these serious risks by providing reliable, timely alerts when early signs of danger are detected. By understanding and managing the hazards of thermal runaway and toxic gas emissions, facilities can maintain a safer working environment and protect against the catastrophic consequences of battery failures.



What to do in case of an alert from EV-Garm

This device senses carbon monoxide from batteries' off-gassing and is not intended to replace carbon monoxide detectors that are intended to protect persons from dangerous carbon monoxide levels.

The vehicle and its batteries being monitored should get attention in response to an alert signal.

Within the vicinity, observe which sensor is alerting attention to a specific vehicle.

If there is visual-heavy smoke from the vehicle (No matter the color)

- 1. Alert all personnel and immediately evacuate the building.*
- 2. Call local emergency services and inform them of the situation and the presence of electrical vehicles.*

Otherwise, ensuring you are not exposed to the smoke, move (do not drive) the vehicle outside the workshop to an open area. Preferably using a chain cable to pull the vehicle.

If you have received the alert via email or SMS.

Alert security or personnel that you know are at the premises of the alerting sensor.

If available, connect to security camera to get a visual overview of the situation.

Relocate to the premises of the sensor and follow the instructions for when you are within the vicinity of an alerting sensor.

If you have a received a fire alarm as well, call local emergency service and inform them of possible fire and presence of electrical vehicles.



System description

Control unit

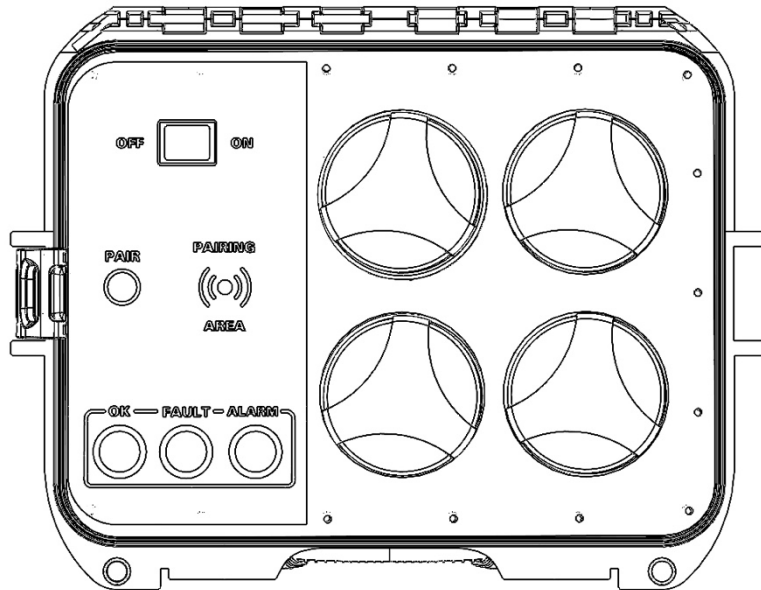

Housed in a robust Suitcase our EV-Garm's main controller unit is securely encased within a protective suitcase with a durable and rugged design. This setup offers high mobility and protection, making it ideal for use in various maintenance environments, particularly those involving electric vehicles.

Integrated Control and Monitoring Features

Sounder and Indicators: The control unit is equipped with an auditory alert signal (sounder) and three color-coded indicators to communicate system status at a glance:

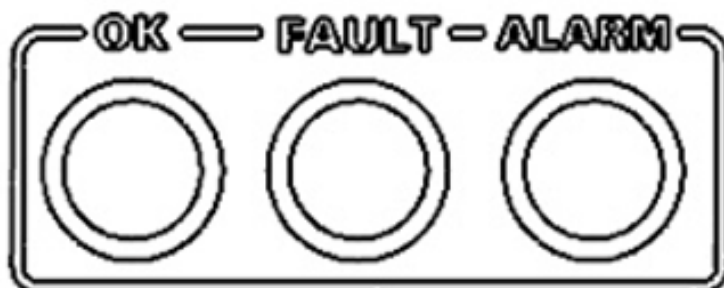

- **Red LED:** Signals an alert condition when carbon monoxide levels suggestive of battery venting are detected.
- **Yellow LED:** Indicates a fault in one or more of the sensor modules or system components, prompting immediate attention.

EV-Garm

- **Green LED:** Confirms that the system is operational, and all monitored conditions are within safe parameters (OK status).

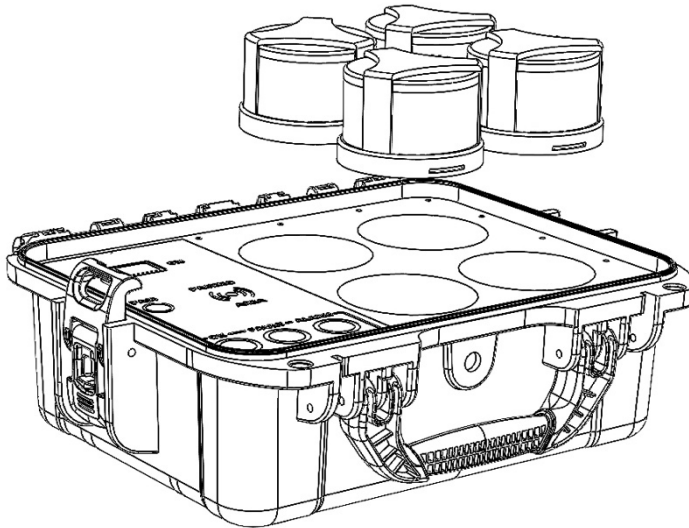

Charging and Maintenance Station The control unit includes four dedicated charging slots, one for each of the carbon monoxide sensor modules. These slots ensure that the sensors are fully charged, maintained, and ready for deployment. The design simplifies the management of the sensor modules, making it easy to keep the system in optimal working condition.

External Power Supply: The control unit is powered by a high quality external power supply, ensuring consistent operation of the system. This setup is designed to provide uninterrupted power to the system, with the added security of internal battery backup that activates should the main power supply fail.



Sensor Module Description

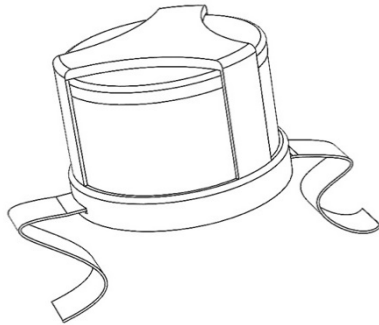

Advanced Electrochemical CO Sensor Each sensor module is equipped with a state-of-the-art electrochemical carbon monoxide sensor, specifically designed for detecting low levels of carbon monoxide with high accuracy and swift response times. This ensures early alert and increased safety in environments prone to battery venting or failure.

Self-Test Sequence Upon the start of each new monitoring session, the sensor performs a comprehensive self-test sequence. This built-in diagnostic check ensures that the sensor has not been damaged and is functioning correctly, maintaining the integrity and reliability of the detection system. This feature is critical for maintaining high safety standards and operational readiness without manual testing.

Wireless Charging Capability The modules are designed with wireless charging capabilities, allowing them to be easily recharged by placing them back in the designated slots within the control unit. This feature simplifies maintenance and ensures the sensors are always ready for use.



LED Status Indicators

- **Red LED:** Indicates detection of carbon monoxide, alerting users to a potential hazardous condition.
- **Yellow LED:** Warns of any faults within the module, prompting immediate attention to ensure continuous protection.
- **Green LED:** Confirms the sensor is operational and monitoring effectively, providing reassurance of system functionality.

Bluetooth Connectivity Communication between the sensor modules and the control unit is facilitated via industry-level Bluetooth, providing a reliable and secure link that supports real-time updates and alerts without the need for physical connections.

Integrated System Functionality

This integration of cutting-edge sensor technology, automatic self-testing, wireless communication, and user-friendly operational features makes our EV-Garm highly effective and easy to manage. Designed for rapid deployment and dependable performance, it is ideally suited for high-stakes environments like electric vehicle maintenance facilities where safety and efficiency are paramount.

Operational Benefits

This configuration not only ensures the system's reliability and effectiveness in detecting hazardous conditions but also provides a portable and secure solution for environments where quick setup and breakdown are essential. The Pelican suitcase enclosure allows for easy transportation and storage, making it a practical choice for service centers and facilities handling electric vehicle maintenance.



Warranty and Spare Parts Information

Warranty Coverage Our EV-Garm comes with a comprehensive one-year warranty that covers any defects in materials and workmanship. This warranty ensures that all components of the system, including the control unit and individual sensor modules, are protected against manufacturing defects from the date of purchase.

What the Warranty Covers:

Replacement or repair of faulty components that fail during normal use, in accordance with the terms and conditions of the warranty.

Labor for repair and parts replacement during the warranty period.

What the Warranty Does Not Cover:

Damage resulting from misuse, neglect, accidents, alterations, improper installation, or unauthorized repairs. Normal wear and tear.

Spare Parts

To enhance the longevity and performance of your EV-Garm, we offer a full range of spare parts, including the sensor modules, sensor filter membrane and power supply. Spare parts are available for order through our customer service or authorized distributors.

Ordering Spare Parts:

To order spare parts, please contact our customer support team with your model number and the specific parts required. Our team is available to assist you in identifying the correct parts to ensure your system remains in optimal working condition.

Spare parts such as sensor module batteries can be ordered if they are lost or damaged. It's advisable to keep spare batteries on hand to avoid any downtime.

Extended Warranty and Service Plans

For added peace of mind, extended warranty options and service plans are available at an additional cost. These plans extend the coverage of your system beyond the standard warranty period and can include services such as regular maintenance checks, updates, and priority technical support.

Customer Support

Our dedicated customer support team is committed to providing high-quality service and support. For any warranty claims, spare part inquiries, or technical assistance, please contact our support team. We are here to ensure your safety system continues to operate effectively and meets your needs.



Guarantee terms and conditions

1. Company, with its registered office in Tyresö Sweden, contact information is available at: www.dafo-vehicle.com (hereinafter "the Manufacturer") guarantees that the device sold (hereinafter: "the Device" is free from material and manufacturing defects.
2. The Manufacturer shall be responsible for malfunctioning of the Device resulting from physical defects inherent in the Device that cause its operation to be incompatible with the specifications within the period of: - 12 months from the date of purchase by a business customer (the consumer and business customer are further collectively referred to as "Customer").
3. The Manufacturer shall remove any defects revealed during the guarantee period, free of charge, by repairing or replacing (at the sole discretion of the Manufacturer) the defective components of the Device with new or regenerated components. The manufacturer reserves the right to replace the entire Device with a new or regenerated device. The Manufacturer shall not refund money paid for the device.
4. Under special circumstances, the Manufacturer may replace the Device with a different device most similar in technical characteristics.
5. Only the holder of a valid guaranty document shall be entitled to make claims under guarantee.
6. Before making a complaint, the Manufacturer recommends using the telephone or online support available at <https://www.dafo-vehicle.com/ev-garm>.
7. In order to make a complaint, the Customer should contact the Manufacturer via the email address given at <https://www.dafo-vehicle.com/ev-garm>.
8. After the complaint has been properly filed, the Customer will receive contact details for the Authorized Guarantee Service ("AGS"). The customer should contact and deliver the Device to AGS. Upon receipt of the Device, the manufacturer shall inform the Customer of the return merchandise authorization number (RMA).
9. Defects shall be removed within 30 days from the date of delivering the Device to AGS. The guarantee period shall be extended by the time in which the Device was kept by AGS.
10. The faulty device shall be provided by the Customer with complete standard equipment and documents proving its purchase.
11. The cost of transporting the Device within Sweden shall be covered by the Manufacturer. The costs of the Device transport from other countries shall be covered by the Customer. For unjustified complaints, AGS may charge the Customer with costs related to the case.
12. AGS shall not accept a complaint claim when:
 - the Device was misused or the manual was not observed,
 - the Device was provided by the Customer incomplete, without accessories or nameplate,
 - it was determined that the fault was caused by other reasons than a material or manufacturing defect of the Device
 - the guarantee document is not valid or there is no proof of purchase,
13. The guarantee shall not cover:



- mechanical damages (cracks, fractures, cuts, abrasions, physical deformations caused by impact, falling or dropping the device or other object, improper use or not observing the operating manual);
 - damages resulting from external causes, e.g.: flood, storm, fire, lightning, natural disasters, earthquakes, war, civil disturbance, force majeure, unforeseen accidents, theft, water damage, liquid leakage, battery spill, weather conditions, sunlight, sand, moisture, high or low temperature, air pollution;
 - damages caused by malfunctioning software, attack of a computer virus, or by failure to update the software as recommended by the Manufacturer;
 - damages resulting from: surges in the power and/or telecommunication network, improper connection to the grid in a manner inconsistent with the operating manual, or from connecting other devices not recommended by the Manufacturer.
 - damages caused by operating or storing the device in extremely adverse conditions, i.e. high humidity, dust, too low (freezing) or too high ambient temperature. Detailed permissible conditions for operating the Device are defined in the technical specifications.
 - damages caused by using accessories not recommended by the Manufacturer
 - damages caused by Customer's failure to provide maintenance and servicing activities defined in the operating manual;
 - damages resulting from the use of spurious spare parts or accessories improper for given model, repairing and introducing alterations by unauthorized persons;
 - defects caused by operating faulty Device or accessories.
14. The guarantee shall not cover natural wear and tear of the Device and its components listed in the operating manual and in technical documentation as such elements have a defined operational life.
15. The Device Guarantee shall not exclude, limit or suspend the Customer's warranty rights.
16. The Manufacturer shall not be liable for damages to property caused by defective device. The Guarantor shall not be liable for indirect, incidental, special, consequential or punitive damages, or for any damages, including, inter alia, loss of profits, savings, data, loss of benefits, claims by third parties and any other damages arising from or related to the use of the Device.

Disclaimer and Safety Information

Battery Condition

The system will alert users of low battery conditions. It is essential to maintain fully charged batteries to ensure continuous operation.

Installation. The apparatus should be installed by a trained professional to ensure correct siting, mounting, and optimal function. Incorrect installation may impair the effectiveness and safety of the device.

Actions on Alerts



If the apparatus issues an alert, immediate action should be taken as outlined in the section *What to do in case of an alert from EV-Garm*. These actions are crucial for ensuring safety and addressing potential dangers promptly.

Visual and Audible Indicators

All visual and audible indicators, including any silencing features, are explained in detail in the section Integrated System Functionality. Users must familiarize themselves with these indicators to correctly interpret alerts and system status.

Environmental Influences

Exposure to materials, vapors, or gases such as those found in cleaning fluids, polishes, paints, and cooking operations may affect the reliability of the apparatus both short and long term. Avoid exposure to such substances.

Risk of Electric Shock or Malfunction

Tampering with the apparatus can result in electric shock or malfunction. Such actions will void any warranty and can compromise the effectiveness of the device.

Apparatus Lifetime

The expected lifetime of the apparatus is three years assuming normal usage and conditions. This is subject to change based on environmental factors and usage patterns.

Operating Conditions

The apparatus is designed to operate within specific temperature and humidity ranges. Operating outside of these conditions can reduce the system's effectiveness.

Frequency Band Usage

The apparatus uses specific frequency bands for WiFi and Bluetooth communication. Ensure compatibility and compliance with local regulations regarding wireless communication.

Assumption of Danger

In the event of an alert, if in doubt always assume the monitored battery is in distress and follow the instructions in section *What to do in case of an alert from EV-Garm*.



Operating Instructions

An instructional video showing the setup and use of the system can be found on <https://www.dafo-vehicle.com/ev-garm>.

Setting Up WiFi and Pairing Your EV-Garm Device

To ensure your EV-Garm is properly configured to communicate through your preferred WiFi network and to manage sensor pairing, follow these detailed steps:

Initial Setup and Pairing Process

Prepare to Pair:

Hold Down the PAIR Button: Before turning on the device, press and hold the PAIR button. Continue to hold it down until you hear a continuous sound, indicating that the device is in pairing mode.

Power On:

Turn on the EV-Garm: Release the PAIR button once the continuous sound can be heard and wait for the device to become silent, signaling that it is ready for the next step.

Connect to Device WiFi:

Locate WiFi Network: On your smartphone or computer, search for a WiFi network named using the EV-Garm's serial number, for example, "EV-60001234".

Connect to the Network: Select the network and connect to it. Note that this WiFi hotspot will remain active for 10 minutes or until you complete the WiFi setup process.

Configure Network Settings

Access the Configuration Page:

Open a web browser and navigate to the EV-Garm's configuration page by entering **http://10.42.0.1** in the address bar. Alternatively, you can:

Place your phone's NFC antenna onto the PAIRING AREA to automatically open the address.

Scan the QR code provided on the device.

Manually type the address into your browser.

Select a WiFi Network:

Choose the Network: From the configuration page, select the WiFi network that the EV-Garm should use for future communications.

Enter WiFi Password: Input the password for your chosen WiFi network.

Finalize Connection:

Connect: After entering the password, press the "CONNECT" button in the browser to finalize the connection to your WiFi network.

Setting Up Email Alerts for EV-Garm

Before you begin, ensure that your smartphone has NFC (Near Field Communication) enabled and is connected to the same WiFi network as your EV-Garm device.



Step-by-Step Guide

Initiate NFC Connection:

Locate the NFC antenna on your phone. This is typically near the top or middle of the device.

Place your phone over the EV-Garm's designated "PAIRING AREA". Note that aligning the NFC antenna correctly may require a few attempts.

Access the Control Panel:

Once the NFC connection is successful, the EV-Garm website will automatically open on your phone's browser. This session will remain active for 10 minutes. If you need more time, you will need to reconnect by repeating Step 1.

Configure Alert Settings:

Enter the email addresses of the recipients who should receive alerts from the EV-Garm.

You can check the current status of the EV-Garm system to ensure it is operating correctly.

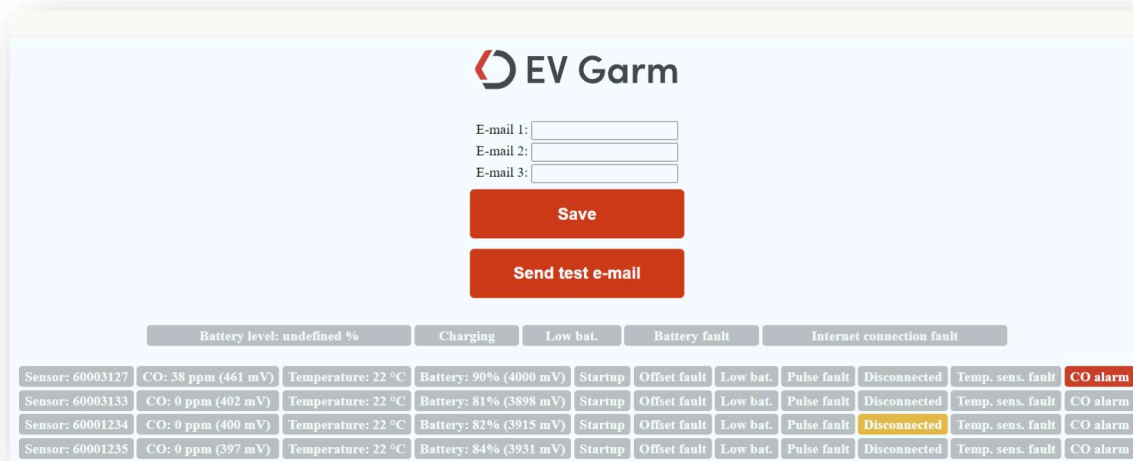

Manage and Monitor:

To view updates or changes to the system's status, refresh the website manually. This is necessary as the webpage does not automatically update.

Reconnecting:

If you wish to make further changes or if the webpage expires, restart the process from Step 1 to re-enable the website and make necessary adjustments.

Note: It's essential to manage and maintain your alert settings regularly to ensure that you receive timely updates regarding your EV-Garm system

How to Activate NFC on Your Mobile Device

NFC (Near Field Communication) allows your phone to communicate with other devices when they're close together. NFC needs to be enabled on your phone to use features like EV-Garm's NFC pairing.



Activating NFC on Android:

Open Settings: Go to the main settings menu on your device.

Connection Settings: Look for the "Connections" section, which might be directly accessible from the settings menu or found under "Network & Internet."

NFC and Payment: Within the connections menu, find the option labeled "NFC" or "NFC and payment." This could also be listed as "More Connection Settings."

Enable NFC: Toggle the switch to enable NFC. Some devices may also offer Android Beam or another file-sharing service that utilizes NFC, which should also be toggled on if you plan to use NFC for sharing.

Activating NFC on iOS (iPhone 7 and later):

NFC is Always On: For iPhones, NFC is enabled by default from iPhone 7 onwards and cannot be turned off. NFC is used for Apple Pay and other background NFC tasks.

Control via Apps: Specific NFC functions are controlled through apps that use NFC. For example, you may be prompted to allow NFC usage when using a particular app like EV-Garm.

General Tips:

Check Phone Compatibility: Not all smartphones have NFC capabilities. Check your device's specifications if you're unsure.

App Permissions: Make sure that any app using NFC has the necessary permissions granted to access NFC features. This can usually be managed in the app settings within your phone.

Protective Cases: Some thick or metal phone cases might block NFC signals. If you're experiencing issues with NFC, try removing the case.

Using NFC:

To use NFC, simply bring your device close to the NFC tag or another NFC-enabled device. The NFC area is typically near the top or middle of your smartphone. Alignment is key, so it may take a few attempts to establish a connection.

Sensor Management

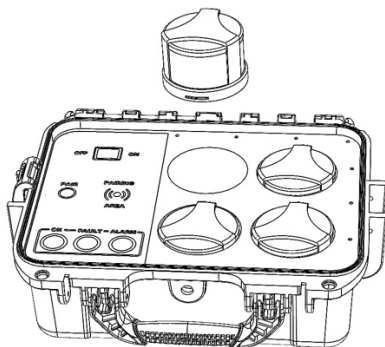

Unpairing Sensors:

Each time a sensor is placed back in its charge slot on the EV-Garm, it is automatically unpaired from the system after 10 sec. This feature ensures that



each sensor is reset and ready for a fresh pairing when next used, enhancing system reliability and performance.

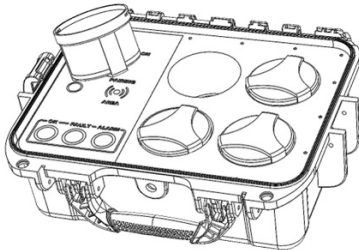

Re-Pairing Sensors:

Before starting a new monitoring session, ensure that each sensor is re-paired following its removal from the charge slot. Repeat the initial setup steps to pair each sensor, ensuring seamless connectivity and accurate monitoring.

Completion

Once connected, the EV-Garm will communicate through the selected WiFi network for all future operations. Ensure the setup process is completed within the 10-minute window before the device hotspot deactivates.



Understanding LED Indicators on Your EV-Garm System

The EV-Garm system uses a series of LED indicators to communicate the device's status and any necessary actions you might need to take. Below is a detailed explanation of what each LED indicator means:

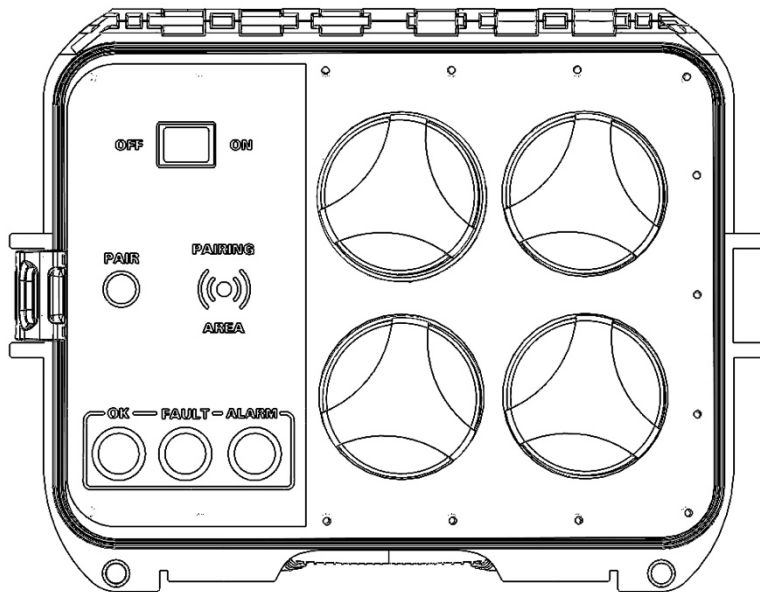

LED Indicator Meanings:

Switched Off:

All LEDs are off. This indicates that the EV-Garm system is completely powered down.

Start-Up Mode:

Steady Green. This color appears when the system is turned on and is going through its initialization process. The steady green light indicates that the system is starting up normally.

Connected & Active:

Blinking Green. A blinking green light signifies that the system is connected to the network and is actively monitoring. This is the normal operational mode when everything is functioning correctly.

Connection Lost, But Active:

Blinking Small Amber. This smaller amber light blinking indicates that the system has lost its network connection but is still active and functioning in a limited capacity. It will continue to monitor using the last known settings.

Fault:

Blinking Amber. If there is a fault within the system, an amber light will blink to alert you. Faults may include sensor errors, power issues, or other system malfunctions.

Alert:



Blinking Red. A blinking red light is used to indicate an urgent alert. This typically involves significant issues such as potential safety hazards or critical operational errors that require immediate attention.

Additional Information on Faults:

To learn more about any faults indicated by a blinking amber light, you can access detailed diagnostic information via the EV-Garm's web server. This information can help you troubleshoot problems and maintain the system effectively.

Action Required:

For any alerts or faults, it is recommended to consult the troubleshooting section of this manual or contact support for assistance in resolving the issue. For red alerts, immediate action may be necessary to ensure safety and prevent damage.

Installation Steps Pre-Usage Preparation

Charge the Sensor:

- i. Storage and Charging: Ensure the sensor is stored inside the control unit suitcase when not in use. The sensor's battery is charged while stored in the suitcase and the suitcase is powered.
- ii. Check Battery Level: Verify that the sensor is fully charged before each usage.
- iii. Pairing the Sensor to the Control Unit:
- iii. Power On the Control Unit: Open the suitcase and turn on the integrated control unit.
- iv. Activate Pairing Mode: Follow the instructions on the control unit to activate pairing mode.
- v. Pair Each Sensor:
- vi. Wait for confirmation on both the sensor and control unit that pairing is successful, indicated by a green light on the sensor.
- vii. Repeat for All Sensors: Repeat the pairing process for all four sensors in the suitcase.



Select the Installation Location

- **Optimal** Position: For best performance, position the sensor within 30 cm of the overpressure valve on the battery pack.
- **Alternative** Position: If there is visible damage (e.g., opening or rupture) to the battery pack, position the sensor close to the damaged area.
- **Floor** Position: Alternatively, the sensor can be placed on the floor just beneath the valve or opening.
- **Multiple** Sensors: Use all four sensors effectively. Place at least two sensors close to the valve/opening for extra safety and accurate detection. If there are several openings/damages, position at least one sensor within 30 cm of each.

Mount the Sensor

- **Prepare** the Mounting Area: Clean the area on the vehicle body where the sensor will be mounted to ensure a secure attachment.
- **Attach** the Mounting Straps:
- **Secure** the mounting straps around the sensor and the vehicle body at the selected location.
- **Adjust** the straps to position the sensor within 30 cm of the overpressure valve, the damaged area, or place it on the floor just beneath the valve/opening.
- **Remove** Obstacles: Ensure there are no obstacles between the sensor and the valve/opening. If the car has a protective cover beneath the chassis covering the battery, it should be removed.

Verify functionality

Ensure that the sensor remains connected to the control unit. The control unit web interface should display the status of each paired sensor, and the sensor should show a green light to indicate it is connected and active.

Positioning Guidance

- **Overpressure** Valve: Position the sensor within 30 cm of the overpressure valve of the battery pack to detect early emissions of CO.
- **Visible** Damage: If there is visible damage to the battery pack, position the sensor close to the damaged area.
- **Floor** Position: Alternatively, place the sensor on the floor just beneath the valve or opening for effective detection.
- **Multiple** Sensors: Use all four sensors effectively. Place at least two sensors close to the valve/opening for extra safety and accurate detection. If there are several openings/damages, position at least one sensor within 30 cm of each.
- **Avoid** Obstacles: Ensure there are no obstacles between the sensor and the valve/opening. Remove any protective covers beneath the chassis if they cover the battery.



Example of Proper Mounting

1. **Identify** the Overpressure Valve: Locate the overpressure valve on the battery pack.
2. **Remove** Obstacles: Ensure there are no obstacles between the sensor and the valve/opening. remove any protective covers beneath the chassis if they cover the battery.
3. **Clean** the Mounting Area: Ensure the area around the valve is clean and free of debris.
4. **Mount** the Sensor: Use the mounting straps to securely attach the sensor within 30 cm of the valve or place it on the floor just beneath the valve/opening.
5. **Verify** Position: Check that the sensor is firmly in place

Handling and Maintenance of Your EV-Garm System

Proper handling and maintenance are crucial to ensuring your EV-Garm system operates effectively and maintains its integrity over time. Adhere to these guidelines to keep your device in optimal condition:

Handling Precautions:

Avoid Obstructions: Do not block the gas sensor ports with any materials such as tape, apparatus, weights, or other objects. This could prevent the sensors from accurately detecting gases.

Silicone and Coatings: Avoid using silicone or other conformal coatings around the sensor port holes. These substances can interfere with the sensors' functionality by impeding gas flow and impair sensor performance.

Chemical Exposure: Refrain from using alcohols and cleaning solutions on or near the sensor tops, as these can degrade sensor materials and impair performance.

General Maintenance Tips:

Regular Cleaning: Use a dry or slightly damp cloth to clean the exterior of the EV-Garm system. Avoid harsh chemicals or abrasive cleaners.

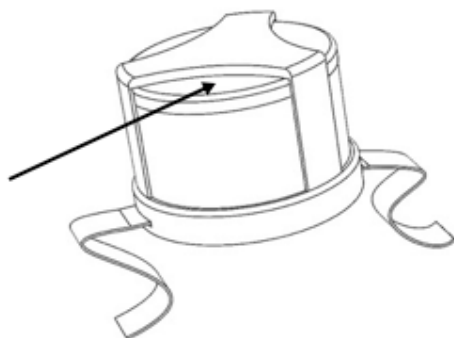



Pay extra attention to the area beneath the red frame that is the inlet to the sensor element. The inlet has a membrane protecting the sensor from water and dirt, which can be replaced if damaged.

Check for Wear: Inspect the device regularly for signs of wear or damage, especially around the sensor ports, to ensure they are not obstructed. If the

Storage Recommendations:

Environmental Control: Store the EV-Garm system in a cool, dry place away from direct sunlight. Extreme temperatures and high humidity can damage the device.

Humidity Control: For long-term storage, consider placing a humidity absorbent inside the case. This will help maintain a dry environment, reducing the risk of moisture-related damage to the sensors and electronic components.

Battery Storage: If the system will not be used for an extended period, ensure the batteries are charged to about 50% to maintain their health.

Sensor Maintenance:

Environmental Monitoring: Avoid placing the device in environments with high concentrations of organic vapors or other interfering gases that could affect sensor readings.

By following these handling and maintenance practices, you can help ensure that your EV-Garm system remains reliable and effective for its intended operational life. Proper care not only extends the life of your device but also ensures it functions correctly when you need it most.

Understanding Cross Sensitivity to Other Gases

Impact of Interfering Gases

The electrochemical sensors used in the EV-Garm system are specifically designed to detect carbon monoxide with high accuracy. However, it is important to note that these sensors can exhibit cross sensitivity to other gases. This means that the presence of other gases, termed as "interfering gases," may cause the sensors to produce false signals, which can be either higher (positive interference) or lower (negative interference) than the actual levels of carbon monoxide.

Awareness of Interfering Gases:

Users should be aware of the types of gases that might be present in the environment alongside the target gas. Common interfering gases include hydrogen, methane, and other volatile organic compounds, which may affect the sensor readings.

Regulatory Compliance

Declaration of Conformity Hereby, Dafo Vehicle Fire Protection AB declares that the device is in compliance with Directives 2014/53/EU and 2011/65/EU, 2015/863. The full text of the EU declaration of conformity is available at the following internet address: www.dafo-vehicle.com/ev-garm



TECHNICAL SPECIFICATIONS

Part number	56-1000-05
Input	100-240VAC, 50/60Hz
Max power consumption	120W
Typical power consumption	5W
Alert sound level	85db @ 3 m with lid open.
Operating temperature	-20 to +40°C
Operating humidity	10-95%RH
Ingress protection	IP 54
Measurement range (CO)	0 - 1000ppm
Sensor battery life	2 weeks
Control unit backup battery	2 days
Weighth	6kg
Dimension	30x20x40 cm
Compliance	<p>RED & EMC ETSI EN 300 328 V2.2.2 ETSI EN 301 489-1 V2.2.3 ETSI EN 301 489-17 V3.2.4 EN IEC 61000-6-2:2019 EN IEC 61000-6-4:2019 ROHS EN IEC 63000:2018</p>
Carbon monoxide sensor element 100% Factory tested	