

FIRE PROTECTION SYSTEMS FOR BUSES AND COACHES



Dafo Vehicle offers the most reliable and effective fire detection and suppression systems for applications in buses, and many other areas.

Most bus fires start in the engine compartment and surrounding areas. Over the years Dafo Vehicle has obtained vast experience and knowledge from our end user installations which have been used as a basis for eliminating false alarms and false releases. As a result of the development Dafo Vehicle can today proudly present state of the art reliable solutions for buses and coaches both without vulnerable and pressurized agent co

The systems are designed to survive demanding conditions, secure the safety of operations and business continuity, as well as the impact on investment.

Dafo Vehicle's robust system not only protects individual hazards within the vehicle, but it is also a system that easily can be maintained and refilled on-site which reduces downtime and operational costs with very low TCO.



DAFO VEHICLE FIRE SUPPRESSION SYSTEMS

A tested and certified fire suppression system in combination with efficient fire detection is the best first line of defence in case of an emergency. The Dafo Vehicle fire suppression system, equipped with a linear heat detector wire, responds immediately to any increase in temperature. Its fully automatic system detects and quickly extinguishes the fire. The suppression agent is released through a pipe system with specially designed nozzles that effectively cover the protected areas. Upon request manual release of the system can be provided.

FORREX EVO - MAKES THE DIFFERENCE

The basis of Dafo Vehicle's system is the suppression agent Forrex EVO which is 100% PFAS free specially developed to suppress fires in combustible engines. Forrex EVO is highly effective on flammable liquid fires like petrol, diesel and hydraulic oils. The system combines the features of liquid and dry chemical, includes unique and propriety tailor-made solutions and offers outstanding flame knockdown and unique protection against re-ignition as it will cool down the overheated engine parts in case of a thermal event.

OCCUPATION SAFETY AND HEALTH (OSH)

The harmless suppression agent and normally non-pressurized containers presents no health risk to operators or staff.

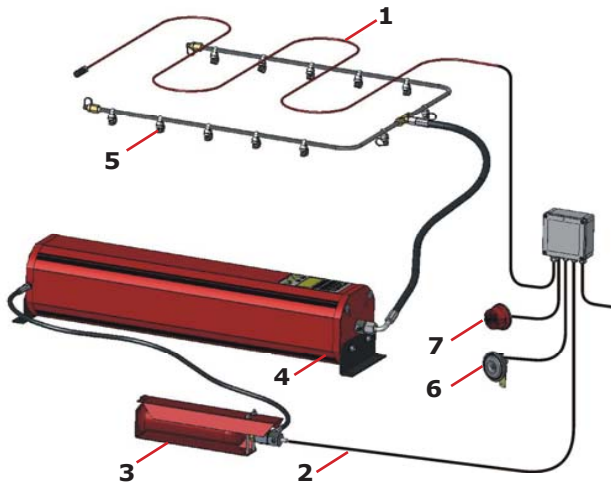

FUNCTION

Fire is indicated by a linear heat detector wire (1) that sends a signal to the actuator (2) which punctures the burst disc of the propellant gas cartridge (3) and releases nitrogen to the agent container (4) that distributes the Forrex agent liquid to the nozzles (5) through the pipe system (8). At the same time the alarm system is activated, an alarm horn (6) in the vehicle and a light signal in the panel will warn the driver (7).

STANDARDS & CERTIFICATES

Standards and regulations are a central part of our business operation and cover most of our products and system designs. Dafo Vehicle honors and fulfills all valid standards and regulations in the markets where we operate. We are constantly working to obtain all relevant certifications where it is applicable. SBF 127 and AS 5062 are some of the certificates that we hold.

BENEFITS

- Strong cooling effect
- Effective Flame Knockdown
- Film forming effect to prevent re-ignition
- Non-pressurized container
- High penetration capability
- Freeze protected down to -50°C
- Easy maintenance
- Easy to clean up after discharge
- Independent system
- Non-corrosive

360° SOLUTION - TOTAL RISK MANAGEMENT SERVICE PROVIDER

Apart from being a supplier of fire suppression systems Dafo Vehicle strives to be a Total Risk Management Service Provider meaning that we offer additional services such as:

- Service and maintenance training
- Technical support
- Risk Analysis
- Customized system design
- Supply chain management



Dafo has been in business for over 100 years and has always been in the front line of technology. The overall objective of Dafo has always been to work with continuous improvements, research, and developments to make our systems more reliable, sustainable and innovative.

